

EMPOWERING OUR WORLD
WITH CLEAN ENERGY



Xiamen Kseng Metal Tech. Co, Ltd

Email: info@xmkseng.com | **Web:** www.xmkseng.com | **Tel:** +86 0592-5795673

Factory Add: No.1021-6, Xiangbei Road, Maxiang Street, Xiangan Dist., Xiamen, Fujian, China.

Office Add: 11&12F, HuixinWealth Centre, No. 891, Fanghu North2nd Rd., Huli Dist., Xiamen, Fujian, China.



EN
DE

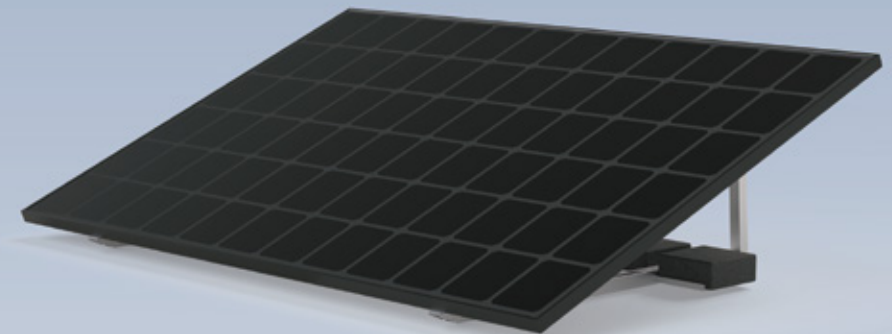

INSTALLATION MANUAL INSTALLATIONSANLEITUNG

Universal Easy Solar Bracket Lite (V2.0)
Universal Einfach Solarhalterung Lite (V2.0)

SC01-EUP020-KS

www.xmkseng.com

1. Installation tools

1. Werkzeuge für die Installation



Tape
Meßband



Socket wrench
Steckschlüssel



Electric drill
Elektrische Bohrmaschine



Rope
Seil

2. Components

2. Komponenten

A x 2



B x 2



C x 4

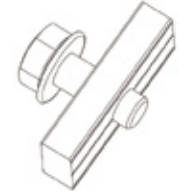

D x 1 (Optional)

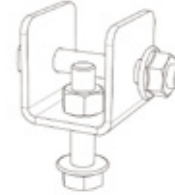

E x 2 (Optional)

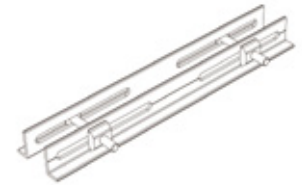

F x 2 (Optional)



G x 4 (Optional)



3.Installation Instruction

3.Installationsanweisung

3.1 Attach two sets of pre-assembled bracket A to the back panel frame as shown in the figure, securing them with four sets of bolt assembly C and tighten the bolts.

3.1 Befestigen Sie zwei vorgefertigte Halterungen A gemäß Abbildung am Rahmen der Rückwand, sichern Sie diese mit vier Schraubensätzen C und ziehen Sie die Schrauben fest.

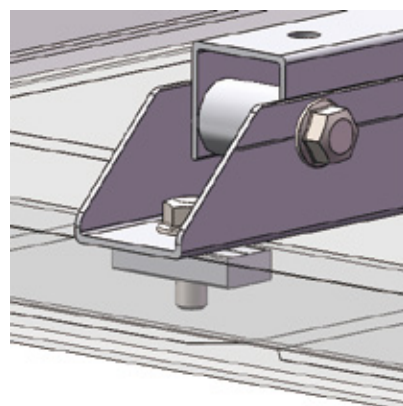
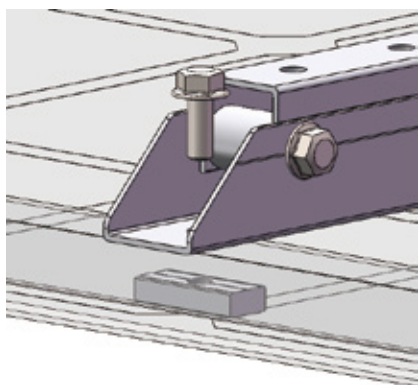
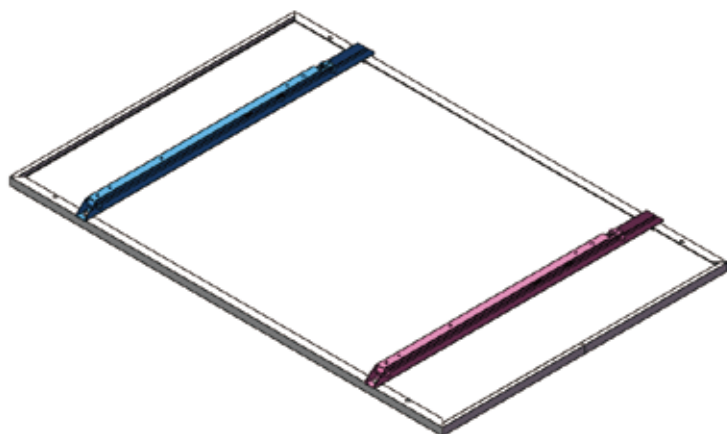

(Please continue reading the content on the back)

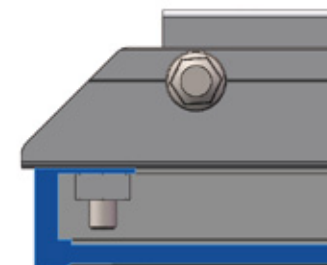
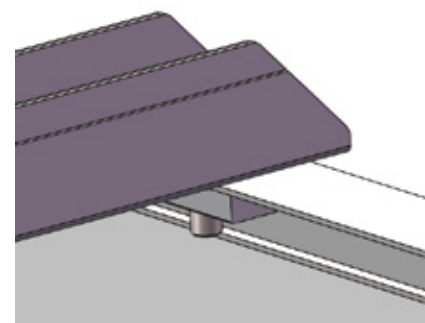

3.2 Unfold the pre-assembled bracket A, and assemble the adjustable leg and the base rail using bolt B as shown below, but do not tighten the bolts yet.

3.2 Entfalten Sie die vorgefertigte Halterung A und setzen Sie den Teleskopstab mit dem Grundstab mittels Schraube B zusammen (siehe Abbildung). Die Schrauben zunächst noch nicht festziehen.

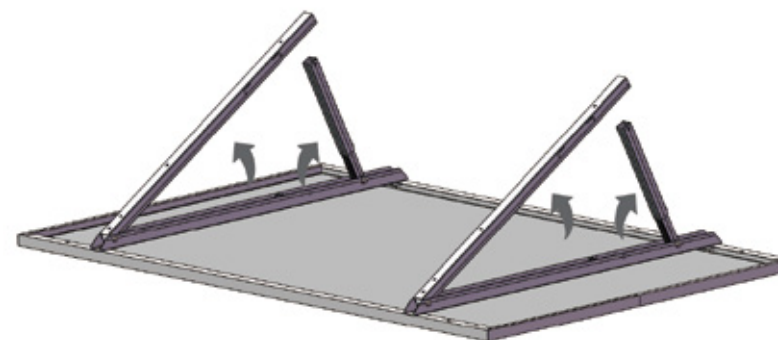

(Please continue reading the content on the back)

3.3 Adjust the adjustable leg to the desired angle, then tighten all bolts securely.

3.3 Verstellen Sie die Teleskopstange auf den gewünschten Winkel und ziehen Sie alle Schrauben fest an.

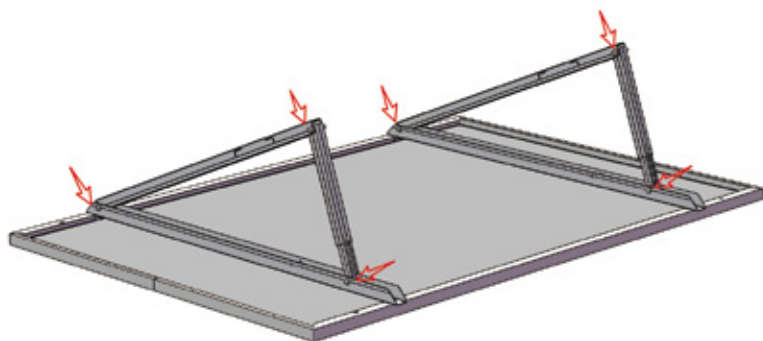
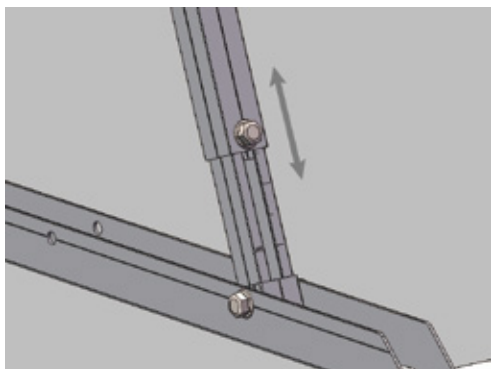

3.4 For microinverter installation, first attach the microinverter accessory to the inclined rail hole as shown, then secure the microinverter with two bolts tightened in sequence. (skip if microinverter accessory is not required). Finally, connect the panel and microinverter wires according to the microinverter wiring instructions.

3.4 Für die Installation des Mikro-Wechselrichters befestigen Sie zunächst die Zubehörteile am schrägen Stangenloch wie dargestellt. Sichern Sie dann den Mikro-Wechselrichter mit zwei nacheinander anzuziehenden Schrauben.(Überspringen, wenn Mikroinverter-Zubehör nicht benötigt wird)

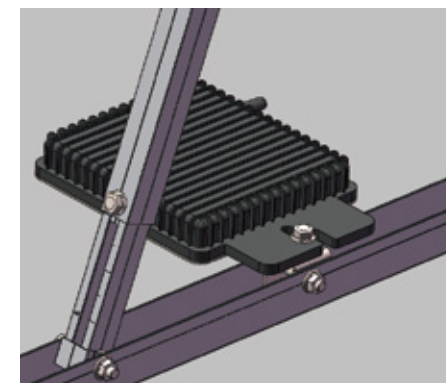
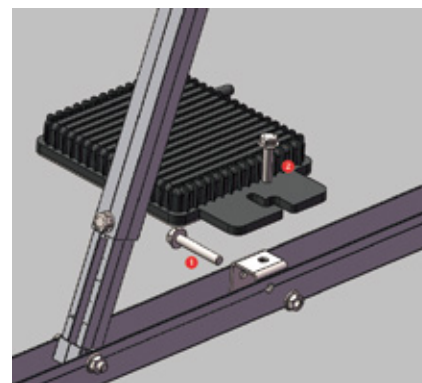

3.5 Installation for Balcony Applications

3.5 Installation für Balkonanwendungen

As shown in the figure, install hook F onto the base rail and tighten the bolts. (skip if hook F is not required)

Wie in der Abbildung gezeigt, die Hakenbaugruppe F auf den Grundstab setzen und die Schrauben fest anziehen.(Überspringen, wenn Haken F nicht benötigt wird).

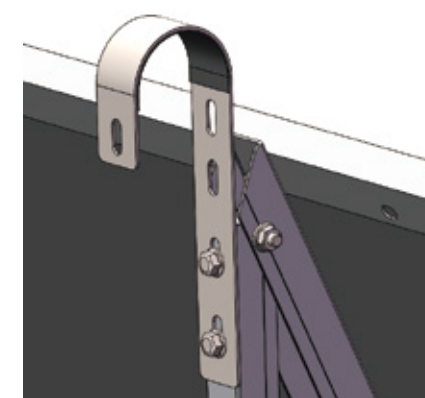
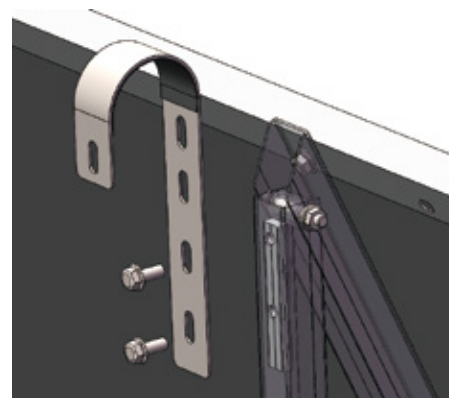

Note: Before fully tightening the bracket, use a rope to secure it when hanging outside the railing to prevent accidental falls from height. Hang the bracket outside the balcony railing and tighten bolts.

Hinweis: Bevor Sie die Halterung vollständig festziehen, sichern Sie sie beim Aufhängen außerhalb des Geländers mit einem Seil, um ein versehentliches Herunterfallen aus der Höhe zu verhindern. Die Halterung außerhalb des Geländers anbringen und die Haken-Verriegelungsbolzen fest anziehen.

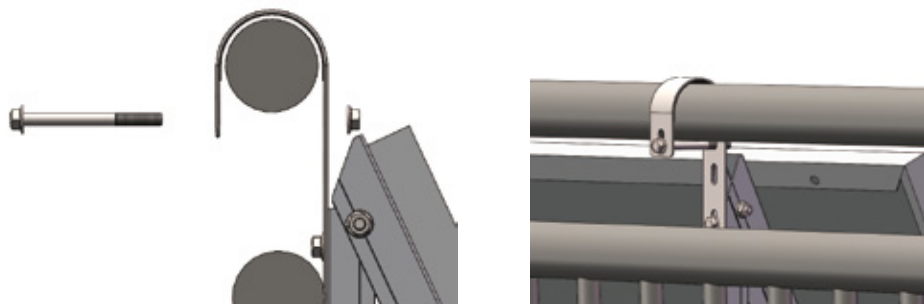

Secure the railing. Insert one bottom fastener E through the base rail, then fix the other one to the vertical railing with bolts and tighten it. (skip if bottom fastener E is not required)

Den unteren Abschnitt sichern. Ein Teil von Bauteil E durch den Grundstab führen, das andere mit Schrauben am Geländerpfosten befestigen. Schrauben fest anziehen.



Complete the remaining microinverter wiring, double-check that all bolts are fully tightened, then remove the auxiliary securing rope. Installation complete.

Verbindung des restlichen Mikro-Wechselrichters vervollständigen, alle Schrauben auf festen Sitz überprüfen und anschließend das Hilfssicherungsseil entfernen. Montage abgeschlossen. (Überspringen, wenn unterer Befestiger E nicht benötigt wird).



3.6 Installation for Wall-mounted Applications

3.6 Installation für Wandmontage

According to the actual situation, first drill expansion bolts into the wall. (skip if expansion bolts is not required). The X spacing corresponds to the hole distance on the back mounting bracket of the panel, and the Y spacing corresponds to the hole distance on the base rail of the bracket.

Gemäß der örtlichen Gegebenheiten zunächst Dübelbolzen in die Wand bohren. (Überspringen, wenn Ausdehnungsschrauben nicht benötigt werden). Der X-Abstand entspricht dem Lochabstand an der Rückhalterung des Moduls. Der Y-Abstand entspricht dem Lochabstand am Grundprofil der Halterung.



Align the bracket with the bolts, then install and tighten the expansion bolt flat washers, spring washers, and nuts.

Halterung an den Dübelbolzen ausrichten, dann Unterlegscheiben, Federringe und Muttern der Expansionsschrauben montieren und fest anziehen.

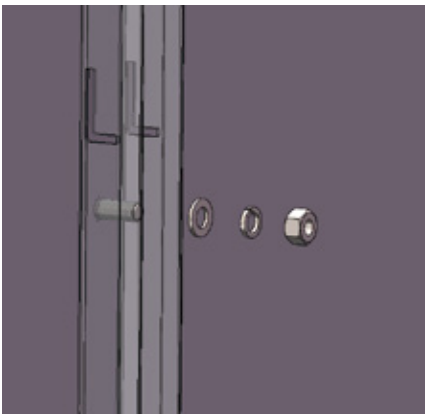

Complete the remaining microinverter wiring, double-check that all bolts are fully tightened. Installation complete.

Restliche Verkabelung des Mikro-Wechselrichters fertigstellen, alle Schraubverbindungen auf festen Sitz überprüfen. Montage abgeschlossen.

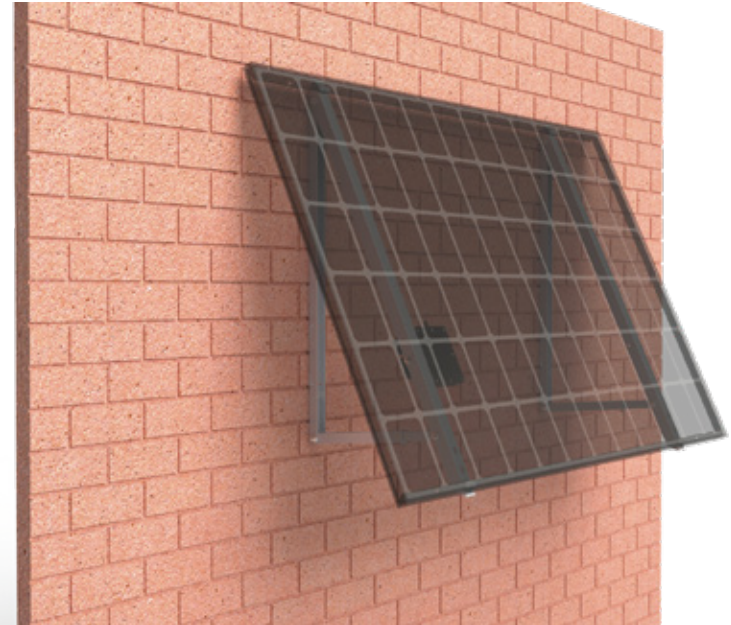

3.7 Installation for ground Applications

3.7 Installation für Flächenmontage

- 1) Secure with expansion bolts. Refer to 5.2 Wall-mounted Installation Application; replace the vertical wall with a horizontal ground, installation method remains the same. (skip if expansion bolts is not required)
- 1) Mit Expansionsdübeln befestigen. Siehe Abschnitt 5.2 Wandmontage – Ersetzen Sie die vertikale Wand durch einen horizontalen Boden, die Montagemethode bleibt identisch. (Überspringen, wenn Ausdehnungsschrauben nicht benötigt werden)

2) For ballast fixing, insert two bottom fastener E into the base rail. Place heavy objects such as bricks on top of the bottom fastener E to stabilize the entire system. The weight should be adjusted according to wind load conditions and is only suitable for areas with low wind loads. In windy areas, it is recommended to use expansion bolts instead.

2) Für Ballastbefestigung zwei Aluminiumwinkel aus Bauteil E in das Grundprofil einsetzen. Schwere Gegenstände (z.B. Ziegelsteine) auf die Aluminiumwinkel legen, um das System zu beschweren. Das Gewicht ist entsprechend der Windlastbedingungen anzupassen und nur für Gebiete mit geringen Windlasten geeignet. In windigen Gebieten wird stattdessen die Verwendung von Expansionsdübeln empfohlen.

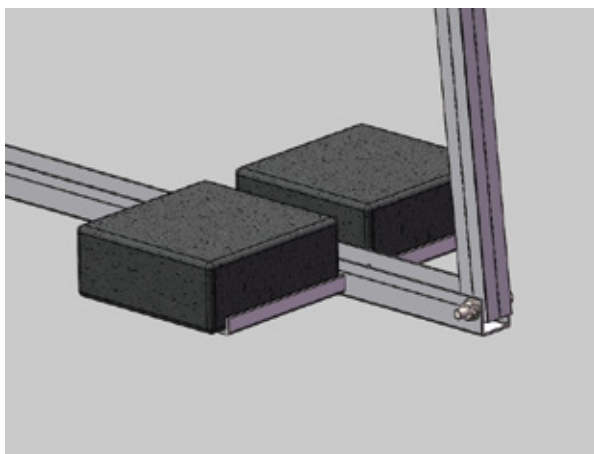
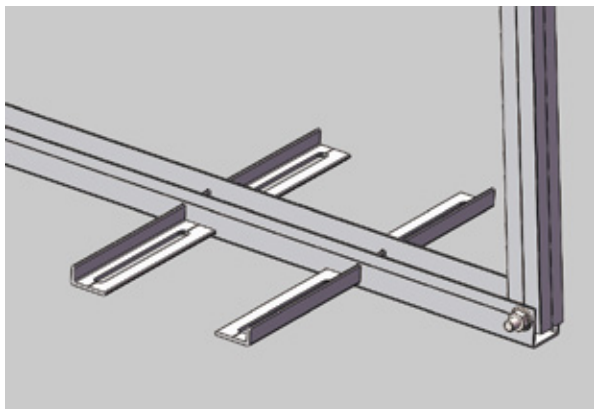

(Please continue reading the content on the back)

Complete the remaining microinverter wiring, double-check that all bolts are fully tightened. Installation complete.

Verkabelung der restlichen Mikro-Wechselrichter vervollständigen und alle Schrauben auf festen Sitz überprüfen. Installation abgeschlossen.

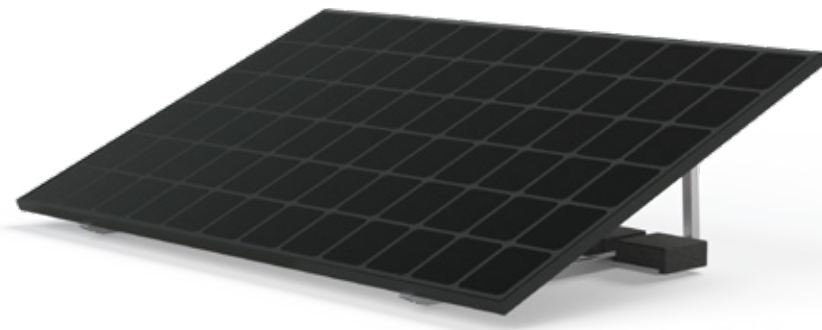

(Please continue reading the content on the back)

Purchaser/End User/Installer Notice:

Purchasers should confirm whether they are able to install this product and obtain relevant permits in accordance with local laws and regulations, including but not limited to government, community, adjacent property owners, and property rights holders.

Purchasers should engage qualified installers, professionals, or self-install only where permitted by law.

Purchasers should also ensure that the installation supports the building or its accessories safely and meets installation requirements, and is sufficient to support the product and its photovoltaic power generation system for over 20 years.

Purchasers should not install or use this product in environments with corrosive air or water, such as acids or alkalis in the vicinity.

Purchasers should fully assess and bear the consequences of product installation and usage and their impact on the surroundings, including but not limited to potential lightning strikes, electrical or magnetic conduction, light reflection/pollution, obstruction of passage, collision with people, snow accumulation and ice shedding, depreciation of buildings, and their consequences.

Purchasers are solely responsible for safety during installation, throughout the installation process, and subsequent usage, and/or any impact on third parties.

After installing the product, purchasers or their appointed installers should carry out waterproof, leak-proof, and anti-seepage construction at the junction of the product and the building to protect the building supporting the product, and conduct periodic inspections and maintenance in the future (at intervals not exceeding 1 year).

Purchasers should be aware that nothing other than the photovoltaic power generation system should be supported on this product, and no additional weight should be placed on the product during installation or subsequent usage, particularly human suspension or leaning. It should not be used for any purpose other than supporting photovoltaic brackets. Purchasers should be aware that nothing other than the photovoltaic power generation battery system should be supported on this product, and no additional weight should be placed on the product during installation or subsequent usage,

particularly human suspension or leaning. It should not be used for any purpose other than supporting photovoltaic brackets.

We shall not be liable for any consequences resulting from failure to comply with local legal requirements and/or failure to follow instructions, warnings, etc., during the installation of this product, nor shall we be liable for any losses to the supporting building or any third party resulting from the installation process or subsequent usage, nor shall we be liable for any multiple installations, disassembly and reuse, or second-hand purchases of this product.

EMPOWERING OUR WORLD
WITH CLEAN ENERGY



Xiamen Kseng Metal Tech. Co, Ltd

Email: info@xmkseng.com | **Web:** www.xmkseng.com | **Tel:** +86 0592-5795673

Factory Add: No.1021-6, Xiangbei Road, Maxiang Street, Xiang'an Dist., Xiamen, Fujian, China.

Office Add: 11&12F, Huixin Wealth Centre, No. 891, Fanghu North 2nd Rd., Huli Dist., Xiamen, Fujian, China.



FR
IT

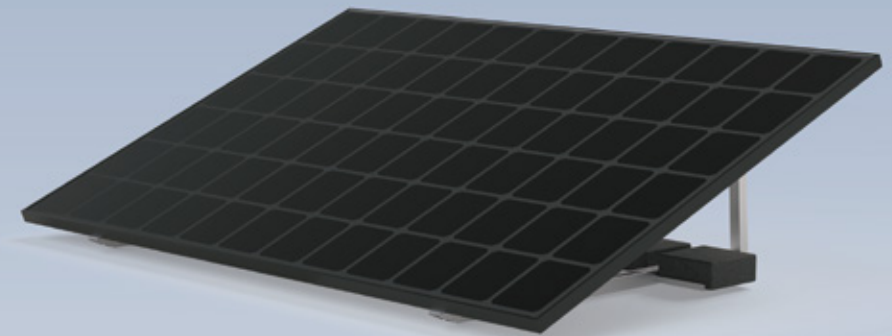

MANUEL D'INSTALLATION MANUALE D'INSTALLAZIONE

Support solaire universel Easy Solar Lite (V2.0)
Supporto Universale Leggero e Pratico (V2.0)

SC01-EUP020-KS

www.xmkseng.com

1. Outils d'Installation

1. Strumenti di installazione



Ruban adhésif
Metro



Clé à douille
Chiave a bussola



Perceuse électrique
Avvitatore elettrico



Corde
Funi di sicurezza ausiliarie

2. Emballage et détails

2. Dettagli dell'imballaggio

A x 2



B x 2



C x 4

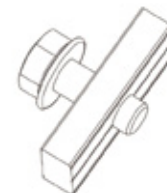

D x 1 (Optionnel / Opzionale)



E x 2 (Optionnel / Opzionale)

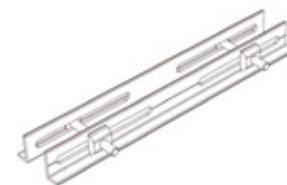

F x 2 (Optionnel / Opzionale)



G x 4 (Optionnel / Opzionale)



3. Instructions d'installation

3. Istruzioni per l'installazione

3.1 Fixez deux ensembles de supports préassemblés A au cadre du panneau arrière, comme illustré, à l'aide de quatre ensembles de boulons C, puis serrez fermement les boulons.

3.1 Fissare i 2 set di supporti preassemblati A sul retro del pannello, come illustrato, utilizzando i 4 set di bulloni C. Serrare i bulloni.

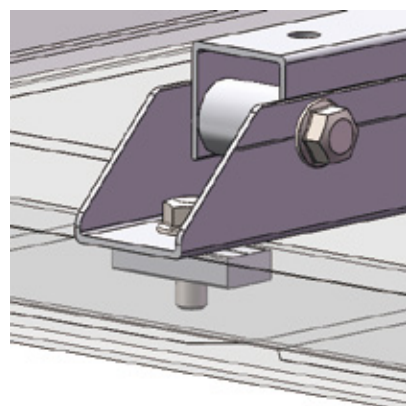
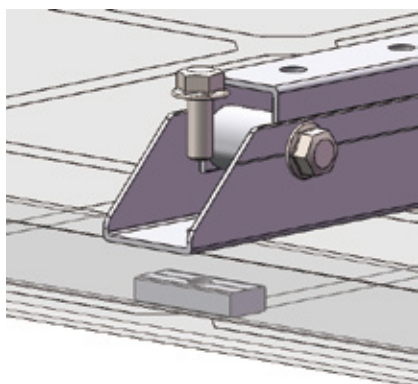
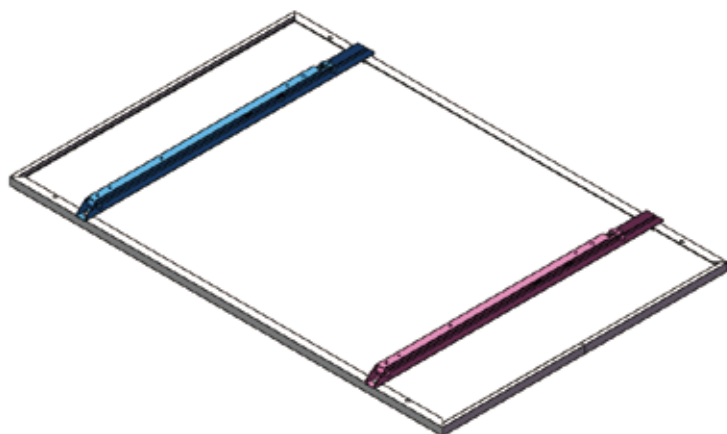

(Please continue reading the content on the back)

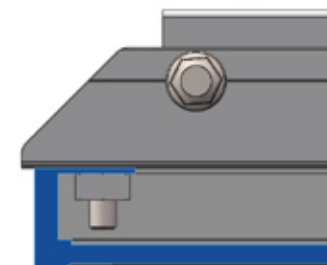
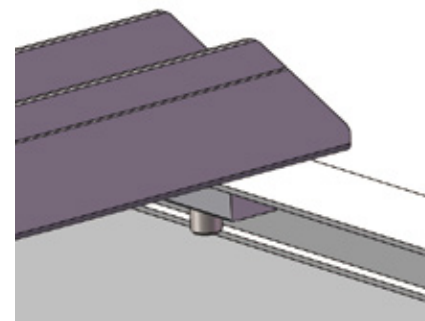

3.2 Dépliez le support pré-assemblé A et assemblez le pied réglable et le rail de base à l'aide du boulon B comme indiqué ci-dessous, mais ne serrez pas encore les boulons.

3.2 Estendere il set A, collegare l'asta estensibile all'asta base mediante il set di bulloni B come mostrato, senza procedere al serraggio.

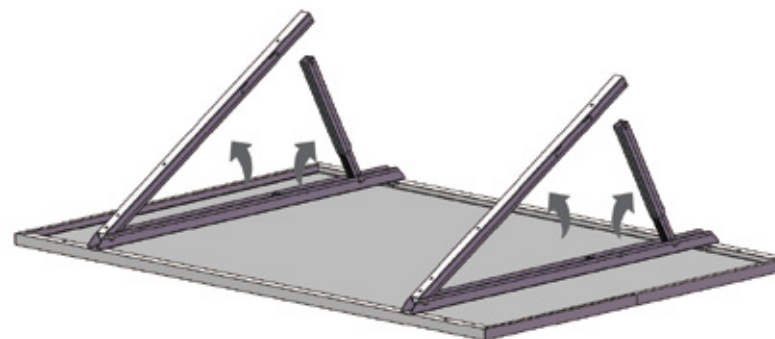

(Please continue reading the content on the back)

3.3 Ajustez le pied réglable à l'angle souhaité, puis serrez fermement tous les boulons.

3.3 Regolare fino al raggiungimento dell'angolazione desiderata, poi serrare definitivamente i bulloni.

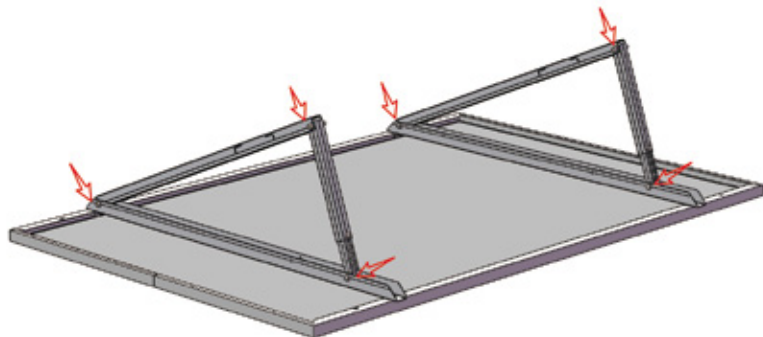
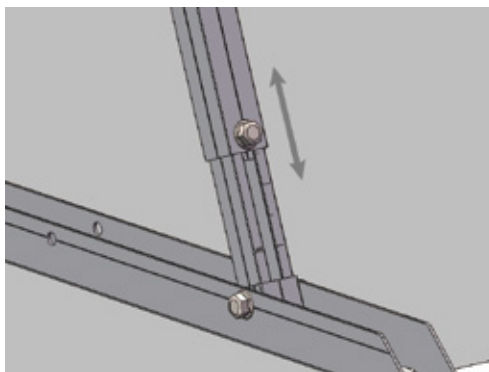

3.4 Pour l'installation du micro-onduleur : fixez d'abord l'accessoire du micro-onduleur au trou du rail incliné comme indiqué, puis fixez le micro-onduleur à l'aide de deux boulons, en les serrant successivement. (Ignorer cette étape si l'accessoire du micro-onduleur n'est pas nécessaire.) Enfin, connectez les fils du panneau et du micro-onduleur conformément aux instructions de câblage du micro-onduleur.

3.4 Installazione del micro-inverter: fissare il micro-inverter come illustrato, quindi collegarlo al pannello seguendo le istruzioni specifiche. (Saltare, se l'accessorio per microinverter non è richiesto)

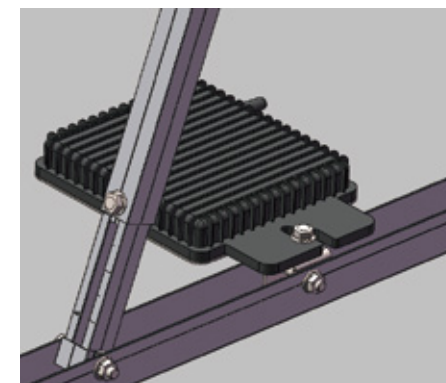
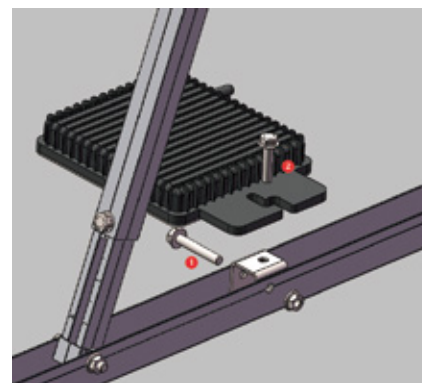

3.5 Installation pour les applications sur balcon

3.5 Installazione sul balcone

Comme indiqué sur la figure, fixez le crochet F sur le rail de base et serrez les boulons. (Ignorer cette étape si le crochet F n'est pas nécessaire.)

Serrare il gancio F all'asta base, poi procedere al serraggio definitivo dei bulloni come illustrato. (Saltare, se il gancio F non è richiesto).

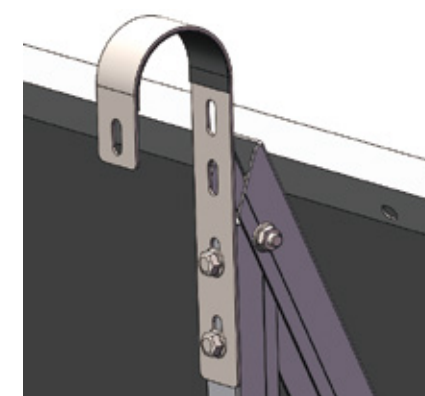
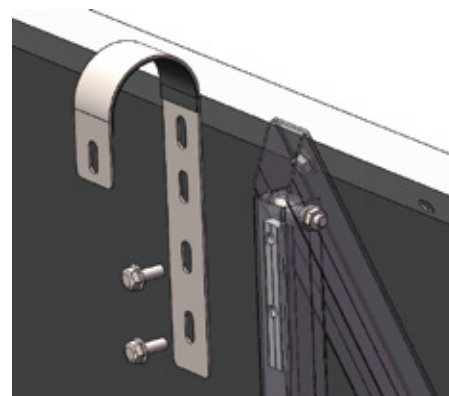

Remarque : avant de serrer complètement le support, utilisez une corde pour le maintenir lorsque vous le suspendez à l'extérieur de la balustrade, afin d'éviter toute chute accidentelle. Ensuite, accrochez le support à l'extérieur de la balustrade du balcon et serrez les boulons.

NOTA: Durante l'installazione, quando si installano i ganci sul lato esterno, utilizzare sempre funi di sicurezza ausiliarie per prevenire la caduta accidentale. Agganciare la struttura al lato esterno della ringhiera e procedere al serraggio definitivo dei bulloni.

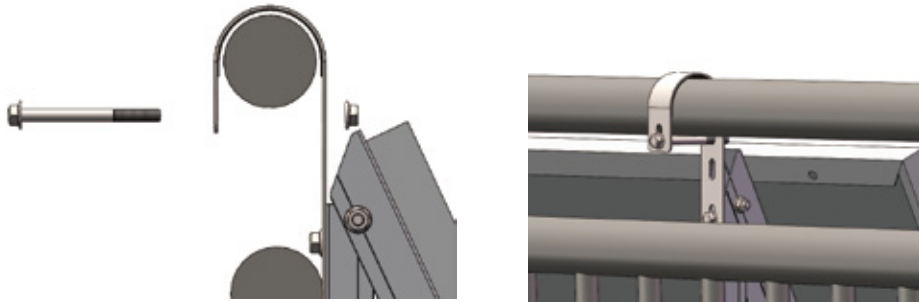

Fixez la rampe : insérez une fixation inférieure E dans la lisse de base, puis fixez l'autre extrémité à la rampe verticale à l'aide de boulons et serrez-les. (Ignorer cette étape si la fixation inférieure E n'est pas nécessaire.)

Fissaggio inferiore: far passare un'estremità del componente E attraverso l'asta base, accostare l'estremità libera al montante del balcone e serrare i bulloni. (Saltare, se il fissaggio inferiore E non è richiesto).

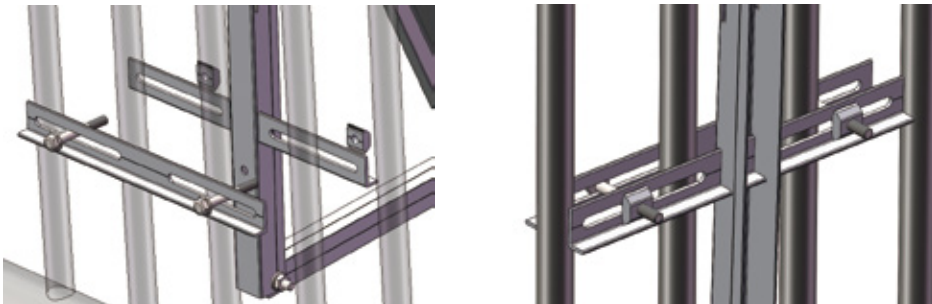

Terminez le câblage restant du micro-onduleur, vérifiez que tous les boulons sont bien serrés, puis retirez le câble de fixation auxiliaire. Installation terminée.

Completare il cablaggio rimanente del microinverter, verificare che tutti i bulloni siano serrati e rimuovere le funi di sicurezza ausiliarie.



3.6 Installation pour les applications murales

3.6 Installazione al muro

Selon la situation réelle, percez d'abord des trous pour les boulons d'expansion dans le mur. (Ignorer cette étape si les boulons d'expansion ne sont pas nécessaires.) L'espacement X correspond à la distance entre les trous sur le support de montage arrière du panneau, et l'espacement Y correspond à la distance entre les trous sur le rail de base du support.

In base alle condizioni reali, installare prima i tasselli a espansione sulla parete. La misura X corrisponde alla distanza dei fori tra i due supporti preassemblati, mentre la misura Y rappresenta la distanza dei fori sull'asta base. (Saltare, se i bulloni a espansione non sono richiesti).



Alignez le support avec les boulons, puis installez et serrez les rondelles plates, les rondelles élastiques et les écrous des boulons d'expansion.

Allineare il supporto ai bulloni a espansione, montare rondella piatta, rondella elastica e dado sui bulloni, e infine serrare il tutto.

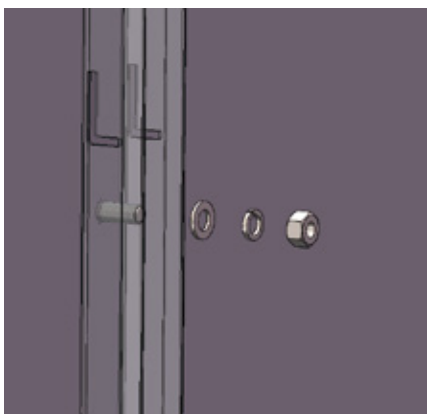

Terminez le câblage restant du micro-onduleur, vérifiez que tous les boulons sont bien serrés. Installation terminée.

Completare il cablaggio rimanente del microinverter, verificare che tutti i bulloni siano serrati e rimuovere le funi di sicurezza ausiliarie.

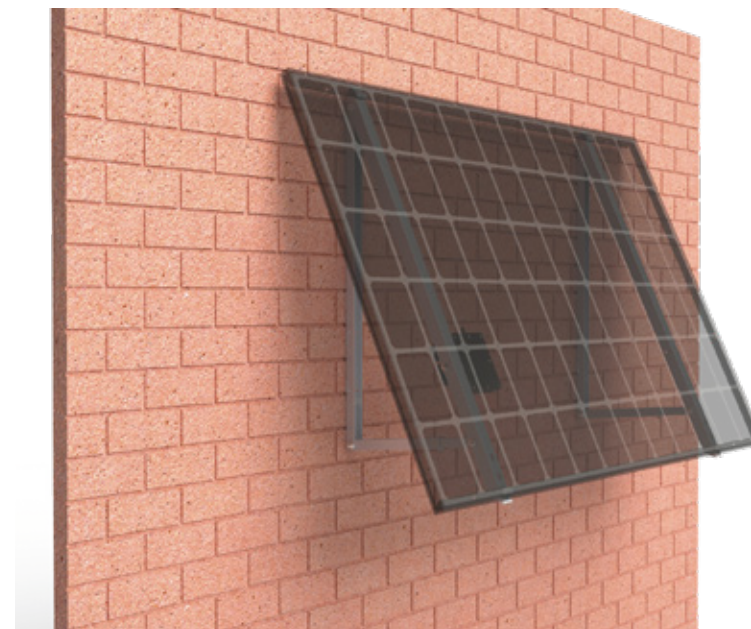

3.7 Installation pour les applications au sol

3.7 Installazione a terra

- 1) Fixation avec des boulons à expansion. Voir 5.2 Installation murale ; remplacer le mur vertical par un sol horizontal ; la méthode d'installation reste la même. (Ignorer cette étape si les boulons d'expansion ne sont pas nécessaires.)
- 1) Fare riferimento alla sezione 5.2 "Installazione a parete" : l'installazione a terra avviene in orizzontale con la stessa metodologia.(Saltare, se i bulloni a espansione non sono richiesti).

- 2). Pour la fixation du ballast : insérez deux fixations inférieures E dans le rail de base. Placez des objets lourds, tels que des briques, sur les fixations inférieures E afin de stabiliser l'ensemble du système. Le poids doit être ajusté en fonction des conditions de vent et cette méthode convient uniquement aux zones à faible exposition au vent. Dans les zones venteuses, il est recommandé d'utiliser des boulons d'expansion.
- 2). Far passare un'estremità del componente E attraverso l'asta base. Posizionare sopra dei pesi (ad esempio mattoni) per stabilizzare l'intero sistema. Il peso necessario è proporzionale al carico vento previsto nella zona di installazione.

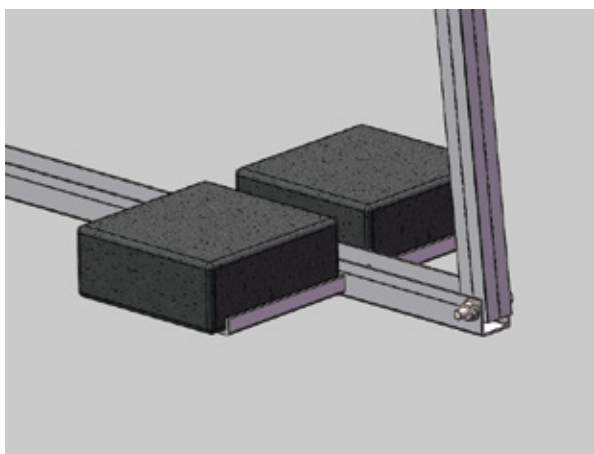
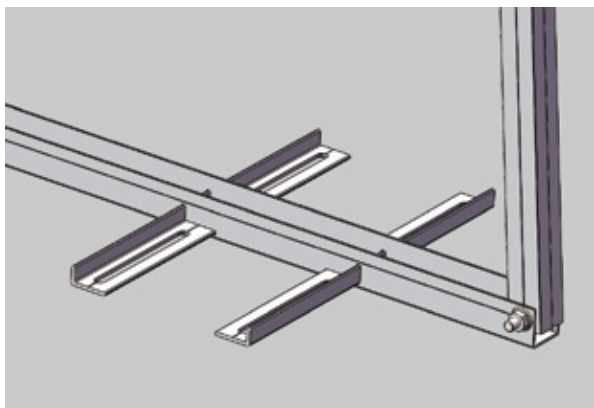

(Please continue reading the content on the back)

Terminez le câblage restant du micro-onduleur, vérifiez que tous les boulons sont bien serrés. Installation terminée.

Completare il cablaggio rimanente del microinverter, verificare che tutti i bulloni siano serrati e rimuovere le funi di sicurezza ausiliarie.



(Please continue reading the content on the back)

Purchaser/End User/Installer Notice:

Purchasers should confirm whether they are able to install this product and obtain relevant permits in accordance with local laws and regulations, including but not limited to government, community, adjacent property owners, and property rights holders.

Purchasers should engage qualified installers, professionals, or self-install only where permitted by law.

Purchasers should also ensure that the installation supports the building or its accessories safely and meets installation requirements, and is sufficient to support the product and its photovoltaic power generation system for over 20 years.

Purchasers should not install or use this product in environments with corrosive air or water, such as acids or alkalis in the vicinity.

Purchasers should fully assess and bear the consequences of product installation and usage and their impact on the surroundings, including but not limited to potential lightning strikes, electrical or magnetic conduction, light reflection/pollution, obstruction of passage, collision with people, snow accumulation and ice shedding, depreciation of buildings, and their consequences.

Purchasers are solely responsible for safety during installation, throughout the installation process, and subsequent usage, and/or any impact on third parties.

After installing the product, purchasers or their appointed installers should carry out waterproof, leak-proof, and anti-seepage construction at the junction of the product and the building to protect the building supporting the product, and conduct periodic inspections and maintenance in the future (at intervals not exceeding 1 year).

Purchasers should be aware that nothing other than the photovoltaic power generation system should be supported on this product, and no additional weight should be placed on the product during installation or subsequent usage, particularly human suspension or leaning. It should not be used for any purpose other than supporting photovoltaic brackets. Purchasers should be aware that nothing other than the photovoltaic power generation battery system should be supported on this product, and no additional weight should be placed on the product during installation or subsequent usage,

particularly human suspension or leaning. It should not be used for any purpose other than supporting photovoltaic brackets.

We shall not be liable for any consequences resulting from failure to comply with local legal requirements and/or failure to follow instructions, warnings, etc., during the installation of this product, nor shall we be liable for any losses to the supporting building or any third party resulting from the installation process or subsequent usage, nor shall we be liable for any multiple installations, disassembly and reuse, or second-hand purchases of this product.